



Alteon OS[™]

Release Notes

Nortel 1/10Gb Uplink Ethernet Switch Module for IBM BladeCenter®

Version 1.0

Part Number: BMD00048, May 2008

BLADE
N E T W O R K
T E C H N O L O G I E S

2350 Mission College Blvd.
Suite 600
Santa Clara, CA 95054
www.bladenetwork.net

Copyright © 2008 Blade Network Technologies, Inc., 2350 Mission College Blvd. Suite 600, Santa Clara, California, 95054, USA. All rights reserved. Reference number: BMD00048

This document is protected by copyright and distributed under licenses restricting its use, copying, distribution, and decompilation. No part of this document may be reproduced in any form by any means without prior written authorization of Blade Network Technologies, Inc. Documentation is provided “as is” without warranty of any kind, either express or implied, including any kind of implied or express warranty of non-infringement or the implied warranties of merchantability or fitness for a particular purpose.

U.S. Government End Users: This document is provided with a “commercial item” as defined by FAR 2.101 (Oct. 1995) and contains “commercial technical data” and “commercial software documentation” as those terms are used in FAR 12.211-12.212 (Oct. 1995). Government End Users are authorized to use this documentation only in accordance with those rights and restrictions set forth herein, consistent with FAR 12.211- 12.212 (Oct. 1995), DFARS 227.7202 (JUN 1995) and DFARS 252.227-7015 (Nov. 1995).

Blade Network Technologies, Inc. reserves the right to change any products described herein at any time, and without notice. Blade Network Technologies, Inc. assumes no responsibility or liability arising from the use of products described herein, except as expressly agreed to in writing by Blade Network Technologies, Inc. The use and purchase of this product does not convey a license under any patent rights, trademark rights, or any other intellectual property rights of Blade Network Technologies, Inc.

Alteon and Alteon OS are trademarks of Nortel Networks, Inc. in the United States and certain other countries. Any other trademarks appearing in this manual are owned by their respective companies.

Originated in the USA.

Release Notes

The Nortel 1/10Gb Uplink Ethernet Switch Module (GbESM) can be installed in any of the IBM BladeCenter chassis.

These release notes provide the latest information regarding Alteon OS for Nortel 1/10Gb Uplink Ethernet Switch Module version 1.0. This supplement modifies information found in the complete documentation:

- Alteon OS *Application Guide* for the Nortel 1/10Gb Uplink Ethernet Switch Module for IBM BladeCenter
- Alteon OS *Command Reference* for the Nortel 1/10Gb Uplink Ethernet Switch Module for IBM BladeCenter
- Alteon OS *ISCLI Reference* for the Nortel 1/10Gb Uplink Ethernet Switch Module for IBM BladeCenter
- Alteon OS *Browser-Based Interface Quick Guide* for the Nortel 1/10Gb Uplink Ethernet Switch Module for IBM BladeCenter
- *BladeCenter Installation Guide* for the Nortel 1/10Gb Uplink Ethernet Switch Module for IBM BladeCenter

The publications listed above are available from the IBM support website:

<http://www.ibm.com/systems/support>

Please keep these release notes with your product manuals.

Hardware support

This Alteon OS version 1.0 software is supported only on the IBM BladeCenter's 1/10Gb Uplink Ethernet Switch Module (GbESM). The GbESM is a high performance Layer 2-3 embedded network switch that features tight integration with IBM BladeCenter's management module. The GbESM has three 10Gb external ports (see [Figure 1](#)) and six 1Gb external ports. The number and type of ports are as follows:

- Three 10Gb SFP+ slots
- Six 1Gb Ethernet ports (RJ45)
- One RS-232 serial console port
- Two 100Mb internal management ports
- Fourteen 1000Mb Ethernet internal ports

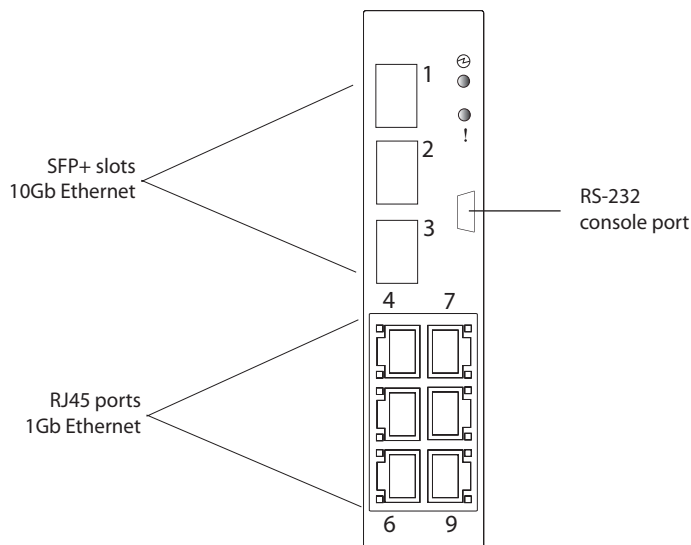

Figure 1 1/10 Uplink Ethernet Switch Module faceplate

Updating the Switch Software Image

The switch software image is the executable code running on the GbE Switch Module. A version of the image ships with the switch, and comes pre-installed on the device. As new versions of the image are released, you can upgrade the software running on your switch. To get the latest version of software available for your GbE Switch Module, go to:

<http://www.ibm.com/systems/support>

Click on **Software Updates**. Use the `/boot/cur` command to determine the current software version.

The typical upgrade process for the software image consists of the following steps:

- Place the new image onto a FTP or TFTP server on your network, or on a local computer.
- Transfer the new image to your switch.
- Select the new software image to be loaded the next time the switch is reset.

Loading New Software to Your Switch

The switch can store up to two different software images, called `image1` and `image2`, as well as boot software, called `boot`. When you load new software, you must specify where it should be placed: either into `image1`, `image2`, or `boot`.

For example, if your active image is currently loaded into `image1`, you would probably load the new image software into `image2`. This lets you test the new software and reload the original active image (stored in `image1`), if needed.

To download a new software image to your switch, you will need the following:

- The image or boot software loaded on a FTP or TFTP server on your network
- The hostname or IP address of the FTP or TFTP server
- The name of the new software image or boot file

NOTE – The DNS parameters must be configured if specifying hostnames.

Image names:

- Image file: `GbESM-1-10U-AOS-1.0.1.0_OS.img`
- Boot file: `GbESM-1-10U-AOS-1.0.1.0_Boot.img`

When the above requirements are met, use the following procedure to download the new software to your switch.

NOTE – When performing this update, make sure you download the new boot file and the new image file.

Using the AOS CLI:

1. **At the Boot Options# prompt, enter:**

```
Boot Options# gting
```

2. **Enter the name of the switch software to be replaced:**

```
Enter name of switch software image to be replaced
["image1"/"image2"/"boot"]: <image>
```

3. **Enter the hostname or IP address of the FTP or TFTP server.**

```
Enter hostname or IP address of FTP/TFTP server: <name or IP address>
```

4. **Enter the name of the new software file on the server.**

```
Enter name of file on FTP/TFTP server: <filename>
```

The exact form of the name will vary by server. However, the file location is normally relative to the FTP or TFTP directory (usually /tftpboot).

5. **Enter your username for the server, if applicable.**

```
Enter username for FTP server or hit return for TFTP server: <user-
name> or <Enter>
```

6. **The system prompts you to confirm your request.**

Use the following procedure to select which OS software image (image1 or image2) you want to run in switch memory for the next reboot.

7. **At the Boot Options# prompt, enter:**

```
Boot Options# image
```

8. **Enter the name of the image you want the switch to use upon the next boot.**

The system informs you of which image is currently set to be loaded at the next reset, and prompts you to enter a new choice:

```
Currently set to use switch software "image1" on next reset.
Specify new image to use on next reset ["image1"/"image2"]:
```

Using the ISCLI:

1. **In Privileged EXEC mode, enter the following command:**

```
Router# copy tftp {<image1|image2|boot-image>}
```

or

```
Router# copy ftp {<image1|image2|boot-image>}
```

2. **Enter the hostname or IP address of the FTP or TFTP server.**

```
Address or name of remote host: <name or IP address>
```

3. **Enter the name of the new software file on the server.**

```
Source file name: <filename>
```

The exact form of the name will vary by server. However, the file location is normally relative to the FTP or TFTP directory (usually `tftpboot`).

4. **Enter your username and password for the server, if applicable.**

```
User name: <username>|<Enter>
```

5. **The system prompts you to confirm your request.**

After loading software to the switch, select a software image to run, as described below.

Use the following procedure to select which OS software image (`image1` or `image2`) you want to run in switch memory for the next reboot.

6. **In Global Configuration mode, enter:**

```
Router(config)# boot image {image1|image2}
```

7. **Enter the name of the image you want the switch to use upon the next boot.**

The system informs you of which image set to be loaded at the next reset:

```
Next boot will use switch software image1 instead of image2.
```

Using the BBI:

You can use the Browser-Based Interface to load software onto the GbESM. The software image to load can reside in one of the following locations:

- FTP server
- TFTP server
- Local computer

After you log onto the BBI, perform the following steps to load a software image:

1. **Click the Configure context tab in the toolbar.**
2. **In the Navigation Window, select System > Config/Image Control.**

The Switch Image and Configuration Management page appears.

Switch Image and Configuration Management									
Image 1 Version	version 1.0.0, downloaded 16:51:09 Sun Jan 8, 2008								
Image 2 Version	version 1.0.1, downloaded 14:08:11 Fri Jan 6, 2008								
Boot Version	version 1.0.0								
Active Image Version	1.0.0								
Next Boot Image Selection	image 1 ▾								
<table border="1"> <tr> <td>Active Configuration Block</td> <td>active config</td> </tr> <tr> <td>Next Boot Configuration Block Selection</td> <td>active config ▾</td> </tr> <tr> <td>Next CLI Boot Mode Selection</td> <td>AOS CLI ▾</td> </tr> <tr> <td>Prompt for selectable boot mode</td> <td>DISABLE ▾</td> </tr> </table>		Active Configuration Block	active config	Next Boot Configuration Block Selection	active config ▾	Next CLI Boot Mode Selection	AOS CLI ▾	Prompt for selectable boot mode	DISABLE ▾
Active Configuration Block	active config								
Next Boot Configuration Block Selection	active config ▾								
Next CLI Boot Mode Selection	AOS CLI ▾								
Prompt for selectable boot mode	DISABLE ▾								
<table border="1"> <tr> <td colspan="2"><u>FTP/TFTP Settings</u></td> </tr> <tr> <td>Hostname or IP Address of FTP/TFTP server</td> <td>100.10.20.1</td> </tr> <tr> <td>Username for FTP Server or Blank for TFTP Server</td> <td></td> </tr> <tr> <td>Password for FTP Server</td> <td></td> </tr> </table>		<u>FTP/TFTP Settings</u>		Hostname or IP Address of FTP/TFTP server	100.10.20.1	Username for FTP Server or Blank for TFTP Server		Password for FTP Server	
<u>FTP/TFTP Settings</u>									
Hostname or IP Address of FTP/TFTP server	100.10.20.1								
Username for FTP Server or Blank for TFTP Server									
Password for FTP Server									
<table border="1"> <tr> <td colspan="2"><u>Image Settings</u></td> </tr> <tr> <td>Image for Transfer</td> <td>image 1 ▾</td> </tr> <tr> <td>Image Filename (on server)</td> <td>1.0.1_OS.img <input type="button" value="Get Image"/> <input type="button" value="Put Image"/></td> </tr> <tr> <td>Image Filename (on HTTP Client)</td> <td><input type="text"/> <input type="button" value="Browse..."/> <input type="button" value="Download via Browser"/></td> </tr> </table>		<u>Image Settings</u>		Image for Transfer	image 1 ▾	Image Filename (on server)	1.0.1_OS.img <input type="button" value="Get Image"/> <input type="button" value="Put Image"/>	Image Filename (on HTTP Client)	<input type="text"/> <input type="button" value="Browse..."/> <input type="button" value="Download via Browser"/>
<u>Image Settings</u>									
Image for Transfer	image 1 ▾								
Image Filename (on server)	1.0.1_OS.img <input type="button" value="Get Image"/> <input type="button" value="Put Image"/>								
Image Filename (on HTTP Client)	<input type="text"/> <input type="button" value="Browse..."/> <input type="button" value="Download via Browser"/>								

3. **If you are loading software from your computer (HTTP client), go to step 4. If you are loading software from a FTP/TFTP server, enter the server's information in the FTP/TFTP Settings section.**
4. **In the Image Settings section, select the image version you want to replace (Image for Transfer).**
 - **If you are loading software from a FTP/TFTP server, enter the file name and click Get Image.**
 - **If you are loading software from your computer, click Browse. In the File Upload Dialog, select the file and click OK. Click Download via Browser.**

Once the image has loaded, the page refreshes to show the new software.

New Software features

The list of features below briefly summarizes the functionality of the 1/10Gb Uplink Ethernet Switch Module (GbESM) in Alteon OS version 1.0.

For more detailed information about configuring GbESM features and capabilities, please refer to the Alteon OS *Application Guide* for the Nortel 1/10Gb Uplink Ethernet Switch Module for IBM BladeCenter.

Switch Management

- IBM management module integration
- BladeCenter Enterprise (BC E, BC H), Telco (BC T, BC HT), and small office (BC S) chassis support
- Browser-Based Interface (HTTP and HTTPS)
- Telnet support
- SSH/SCP support (version 1 and version 2)
- RADIUS authentication and authorization
- TACACS+ authentication and authorization
- LDAP authentication
- SNMP v1/v2c and v3 support
- FTP/TFTP image and configuration management
- Scriptable configuration management
- Protected mode

Layer 2

- 1024 Virtual LANs (VLANs)
- VLAN Tagging
- Protocol-based VLANs
- Private VLANs
- Spanning Tree Protocol
- Rapid Spanning Tree Protocol and Multiple Spanning Tree Protocol

- PVST+ compatibility
- Trunking (port aggregation)
- Link Aggregation Control Protocol (LACP)
- Layer 2 Trunk Failover
- 802.1X Port Authentication (EAPOL)
- QoS/ACL Layer 2 Filtering
- 802.1p/Class Of Service support
- Fast Uplink Convergence

Layer 3

- 128 IP Interfaces
- IP Routing
- Inter-VLAN routing
- 128 static routes
- RIP v1 and v2
- OSPFv2
- BGPv4
- Differentiated Services
- IGMP Snooping, including IGMPv3 Snooping
- IGMP Relay

High Availability

- Virtual Router Redundancy Protocol (VRRP)
- Active-Active support

Security

- Broadcast Storm Control
- Secure switch administration

BC-S chassis support

Alteon OS version 1.0 supports the BladeCenter BC-S chassis. When the GbESM is installed in the BC-S chassis, the following information displays reflect the BC-S port mapping:

- Port link information (/info/link) for switches installed in bay 1 and bay 2:

Alias	Port	Speed	Duplex	Flow Ctrl		Link
----	----	-----	-----	--TX--	--RX--	-----
INT1A	1	1000	full	yes	yes	up
INT1B	2	1000	full	yes	yes	up
INT2A	3	1000	full	yes	yes	up
INT2B	4	1000	full	yes	yes	up
INT3A	5	1000	full	yes	yes	down
INT3B	6	1000	full	yes	yes	up
INT4A	7	1000	full	yes	yes	up
INT4B	8	1000	full	yes	yes	up
INT5A	9	1000	full	yes	yes	up
INT5B	10	1000	full	yes	yes	up
INT6A	11	1000	full	yes	yes	up
INT6B	12	1000	full	yes	yes	up
SMGT1	13	1000	full	yes	yes	up
SMGT2	14	1000	full	yes	yes	up
MGT1	15	100	full	yes	yes	up
EXT1	17	10000	any	yes	yes	up
EXT2	18	10000	any	yes	yes	up
EXT3	19	10000	any	yes	yes	up
EXT4	20	1000	any	yes	yes	up
EXT5	21	1000	any	yes	yes	up
EXT6	22	1000	any	yes	yes	up
EXT7	23	1000	any	yes	yes	up
EXT8	24	1000	any	yes	yes	up
EXT9	25	1000	any	yes	yes	up

- Port link information (/info/link) for switches installed in bay 3 and bay 4:

Alias	Port	Speed	Duplex	Flow Ctrl		Link
----	----	-----	-----	--TX--	--RX--	-----
INT1	1	1000	full	yes	yes	up
INT2	2	1000	full	yes	yes	up
INT3	3	1000	full	yes	yes	down
INT4	4	1000	full	yes	yes	up
INT5	5	1000	full	yes	yes	up
INT6	6	1000	full	yes	yes	up
MGT1	15	100	full	yes	yes	up
EXT1	17	10000	any	yes	yes	up
EXT2	18	10000	any	yes	yes	up
...						

■ Port information (/info/port) for switches installed in bay 1 and bay 2:

Alias	Port	Tag	Fast	Lrn	Fld	PVID	NAME	VLAN(s)
INT1A	1	y	n	e	e	1	INT1A	1 4095
INT1B	2	y	n	e	e	1	INT1B	1 4095
INT2A	3	y	n	e	e	1	INT2A	1 4095
INT2B	4	y	n	e	e	1	INT2B	1 4095
INT3A	5	y	n	e	e	1	INT3A	1 4095
INT3B	6	y	n	e	e	1	INT3B	1 4095
INT4A	7	y	n	e	e	1	INT4A	1 4095
INT4B	8	y	n	e	e	1	INT4B	1 4095
INT5A	9	y	n	e	e	1	INT5A	1 4095
INT5B	10	y	n	e	e	1	INT5B	1 4095
INT6A	11	y	n	e	e	1	INT6A	1 4095
INT6B	12	y	n	e	e	1	INT6B	1 4095
SMGT1	13	y	n	e	e	1	SMGT1	1 4095
SMGT2	14	y	n	e	e	1	SMGT2	1 4095
MGT1	15	y	n	e	e	4095*	MGT1	4095
EXT1	17	n	n	e	e	1	EXT1	1
EXT2	18	n	n	e	e	1	EXT2	1
EXT3	19	n	n	e	e	1	EXT3	1
EXT4	20	n	n	e	e	1	EXT4	1
EXT5	21	n	n	e	e	1	EXT5	1
EXT6	22	n	n	e	e	1	EXT6	1
EXT7	23	n	n	e	e	1	EXT7	1
EXT8	24	n	n	e	e	1	EXT8	1
EXT9	25	n	n	e	e	1	EXT9	1

■ Port information (/info/port) for switches installed in bay 3 and bay 4:

Alias	Port	Tag	Fast	Lrn	Fld	PVID	NAME	VLAN(s)
INT1	1	y	n	e	e	1	INT1	1 4095
INT2	2	y	n	e	e	1	INT2	1 4095
INT3	3	y	n	e	e	1	INT3	1 4095
INT4	4	y	n	e	e	1	INT4	1 4095
INT5	5	y	n	e	e	1	INT5	1 4095
INT6	6	y	n	e	e	1	INT6	1 4095
MGT1	15	y	n	e	e	4095*	MGT1	4095
EXT1	17	n	n	e	e	1	EXT1	1
EXT2	18	n	n	e	e	1	EXT2	1
...								

Supplemental Information

This section provides additional information about configuring and operating the GbESM and Alteon OS version 1.0.

Management Module

- The “Fast POST=Disabled/Enabled” inside the IBM management module Web interface “I/O Module Admin Power/Restart” does not apply to the GbESM.
Solution: To boot with Fast or Extended POST, go to the “I/O Module Admin Power/Restart” window. Select the GbESM, and then choose “Restart Module and Run Standard Diagnostics” or “Restart Module and Run Extended Diagnostics.”
- The following table correlates the Firmware Type listed in the IBM management module’s Web interface “Firmware VPD” window to the GbESM software version:

Table 1 Firmware Type list

Firmware Type	Description
Boot ROM	GbESM Boot code version
Main Application 1	Active image GbESM Alteon OS version
Main Application 2	Backup Image GbESM Alteon OS version

- Within the IBM management module Web interface, the Java applets of “Start Telnet Session” and “Start Web Session” do not support changing of default known ports 23 and 80 respectively.
Solution: If the Telnet or HTTP port on the GbESM is changed to something other than the default port number, the user must use a separate Telnet client or Web browser that supports specifying a non-default port to start a session to the GbESM user interface.

Management Module-GbE Switch Module Connectivity

Currently, the IBM management module is designed to provide one-way control of the GbESM. As a result, the GbESM may lose connectivity to the management module via the management port under the following conditions:

- If new IP attributes are pushed from the management module to the GbESM while the IP Routing table is full with 2048 entries, the new attributes will not be applied.

Solution: Enable “External Management over all ports,” connect to the switch using other interface and then clear the routing table. Then push the IP address from the management module. If this does not work, use Solution 2 below.

- If you execute the /boot/reset CLI command on the GbESM or the GbESM resets itself, the management module might not push the IP attributes to the switch, and connectivity may be lost.

Solution 1: If you should experience any connectivity issues between the switch module and the management module, go to the **I/O Module Configuration** window on the management module’s Web interface. Under the **New Static IP Configuration** section, click Save to trigger the management module to push the stored IP attributes to the switch module.

Solution 2: If Solution 1 does not resolve your connectivity issue, then go to the **I/O Module Admin/Power/Restart window** on the management module’s Web interface. Restart the switch module in question.

Solution 3: If this still does not resolve the issue, enable **Preserve new IP configuration on all resets** setting on the management module and restart the switch module via the **I/O Module Admin/Power/Restart** window on the management module’s Web interface.

NOTE – As a rule, always use the management module Web interface to change the GbESM management IP attributes (IP address, mask and gateway), and then click Save to push the IP attributes to the switch module. Use of the command-line interface to change the switch module management IP attributes may result in duplicated IP Interface 128 entries in the GbE Switch route table and/or loss of connectivity via the management module.

Secure Management Network

The following GbESM attributes are reserved to provide secure management access to and from the IBM management module:

- VLAN 4095
- IP Interface 128
- Gateway 4
- MGT (port 15 and port 16)
- STG 128

For more information about remotely managing the GbESM through the external ports, see “Accessing the Switch” in the Alteon OS version 1.0 *Application Guide*.

NOTE – The external uplink ports (EXT1-EXT9) cannot be members of the management VLAN (4095).

Secure Shell (SSH)

Because SSH key generation is CPU intensive, the GbESM attempts to avoid unnecessary key generation. The process generates three server keys:

1. **One key is generated to replace the current server key, if used.**
2. **A second key is generated as a spare, in case the current server key is used and the specified interval expires.**
3. **A third key is generated for use at the next reboot.**

Therefore, if you never login via SSH, you will only see two key generation events. You may see all three events directly following a reboot. If you want to witness the key generation after the specified interval has expired, then you must login via SSH at least once during each expiration interval.

Trunk Group Configuration Tips

Please be aware of the following information when you configure trunk groups:

- Always configure trunk groups first on both ends, before you physically connect the links.
- Configure all ports in a trunk group to the same speed. You cannot aggregate Gigabit ports with 10GBASE-SFP+ ports (EXT1, EXT2, EXT3).

Spanning Tree Configuration Tips

To ensure proper operation with switches that use Cisco Per VLAN Spanning Tree (PVST+), you must do one of the following:

- Create a separate Spanning Tree Group for each VLAN.
- Manually add all associated VLANs into a single Spanning Tree Group.

When using Layer 2 Trunk Failover, disable Spanning Tree Protocol on external ports.

Syslog Configuration Tip

The *facility* parameter traditionally is used to correlate services (e.g. IP, CLI, etc.) to messages. This is done to distinguish between the different services that are running in the network/device. However, for the GbESM, there is a single configured facility value (0-7) used on all messages. By configuring a unique facility value for each switch, a single SYSLOG server can distinguish between the various GbESMs in the network. Refer to “System Host Log Configuration” in the Alteon OS version 1.0 *Command Reference*.

FTP/TFTP directory path using forward slash

When you use the CLI to perform a FTP/TFTP file transfer, you cannot use a forward slash (/) in the directory path, unless it is preceded by a back slash (\). This issue occurs only when a full command is issued on one line.

Invalid example:

```
/boot/gtimg 1 10.10.10.2 image_directory/filename
```

Valid example:

```
/boot/gtimg 1 10.10.10.2 image_directory\filename
```

Known issues

This section describes known issues for the GbESM and Alteon OS.

ACL Filtering

- When an ACL is installed on two different ports, only one statistics counter will be available. The GbESM does not support two different statistics counter for one ACL installed on two different ports. (Hardware Limitation)
- When setting up an ACL to set 802.1p priority for in-profile packets, and updating DSCP field using TOS bits for out-of-profile packets, the out-of-profile packets will have also the 802.1p priority set based on the in-profile setting. (Hardware limitation)
- Although the management port can be configured for port filtering, actual port filtering will not occur, because the system filters out the management VLAN.

IGMP relay

- When having joins from multiple VLAN's and the multicast data transmitter is on a VLAN that did not receive any joins, multicast data is routed only if the flood option is disabled using the following command
`/cfg/13/igmp/adv/flood d`
- If an IGMP v2 joins an IGMP group on the same port where a v1 join has already been issued, the software will default to the v1 timeout value.

Interoperability with Older Hubs

The command-line interface might display link up and link down messages continuously for an external port that is connected to certain older hub models configured for 100 Mbps half-duplex. The display might show link up erroneously. This behavior has been observed when connecting the GbESM with the following devices:

- NETGEAR FE104 100 hub
- SBS 1000Base-T NIC
- 3Com Linkbuilder FMS100 Hub 3C250 TX/I
- 3Com SuperStack II 100TX 3C250C-TX-24/12
- Nortel Baystack 204 Hub

If the GbESM is connected to an Alteon Application Switch which requires a link speed of 100 Mbps half-duplex, then enable auto negotiation on the GbESM port with `port speed=any, mode=any, fctl=both, and auto=on`.

Link Aggregation Control Protocol

If a static trunk on a GbESM is connected to another GbESM with LACP configured (but no active LACP trunk), the command `/info/12/trunk` might erroneously report the static trunk as forwarding.

Since LACP trunks use LACPDU packet to maintain trunking with the partner, there is a possibility for those packets to be dropped from an extremely busy trunk. If this happens, some links in the LACP trunk might be removed, then aggregated back to the trunk if an LACPDU is received. To avoid this unstable LACP trunk link, you can add more links to the trunk to increase the bandwidth, or use regular static trunk if there are no more links available.

Linking at 10/100Mb

When the link speed for an external connection is forced (i.e. no Auto-Negotiation) to 100 Mbps and then changed to 10 Mbps, if the external device is changed first, the external device may erroneously report the link as DOWN even after the GbESM is changed to 10 Mbps.

Solution: At the external device, disconnect and reconnect the cable.

Static MRouter

If a port has a static multicast router (MRouter) configured, and you move the port to a different VLAN, the static MRouter appears in the `/info/13/igmp/mrouter/dump` output for the original VLAN.

Solution: When you move the port to a new VLAN, remove the static MRouter from the port, and add it again.

ACL Filters

The ACL filters for TCP/UDP work properly only on packets that do not have IP options.

QoS Metering

Traffic may exceed the configured maximum burst size of the ACL meter (`/cfg/port x/aclqos/meter/mbsize`) by one packet, with that packet remaining In-Profile. Once the ACL meter has been exceeded, additional burst packets fall Out-of-Profile.

QoS and Trunking

When you assign an ACL (or ACL Group) to one port in a trunk, Alteon OS does not automatically assign the ACL to other ports in the trunk, and it does not prompt you to assign the ACL to other ports in the trunk.

Solution: Manually assign each ACL or ACL Group to all ports in a trunk.

RADIUS with SSHv2

With RADIUS turned on, users might see a duplicate login prompt for SSHv2 clients, if the RADIUS server is too slow to respond or if the RADIUS server is not available. In this case, users must re-type the username and password to login.

RIP MIBs

Due to backward-compatibility issues, two Routing Information Protocol (RIP) MIBs are available in Alteon OS : `ripCfG` and `rip2CfG`. Use the `rip2CfG` MIB to configure RIPv1 and RIPv2 through SNMP.

Alteon OS does not support the standard RIPv2 MIB, as described in RFC 1724. Use the `rip2CfG` MIB to configure RIPv1 and RIPv2 through SNMP.

Trunk and Link Loop

When you create a trunk or link loop between the GbESM and another switch, packets might loop infinitely at line rate within the related links. When this problem occurs, the GbESM continuously displays the following messages at the console:

```
WARNING: packet_sent u: 0, dv_active: tx ring full  
packet_sent dcnt=114, public1=110, vcnt=1025
```

Solution: Remove the loop to resolve this misconfiguration.

Trunk Traffic

Multicast, broadcast and DLF (Destination Lookup Failure, which are unknown destination MAC packets) traffic is sent to the lowest numbered port in the trunk. If this port is down, then the traffic is sent to the next lowest-numbered port. If the port that was down comes up again, the traffic is not re-hashed back to the recovered port.

Browser Based Interface

- Users with Operator privileges may not make any changes to switch configuration in the BBI.
- Some versions of Microsoft Internet Explorer version 6.x do not perform HTTP download efficiently. If you have one of these versions, HTTP software download might take much longer than expected (up to several minutes).
- Blade Network Technologies recommends the Mozilla Firefox browser for BBI use.

Strong Password expiration

If you configure a Strong Password with automatic expiration, the password might not expire if the system date and time is not configured first. Use of a Network Time Protocol (NTP) server resolves this issue.

Solution: When you configure a strong password with automatic expiration, first configure the system time and date for the switch.

