

RackSwitch™ G8000

# Installation Guide

---

Part Number: BPP-00007-01, December 2009

**BLADE**  
NETWORK TECHNOLOGIES

2350 Mission College Blvd.  
Suite 600  
Santa Clara, CA 95054  
[www.bladenetwork.net](http://www.bladenetwork.net)

Copyright © 2009 BLADE Network Technologies, Inc., 2350 Mission College Blvd., Suite 600, Santa Clara, California, 95054, USA. All rights reserved. Part Number: BPP-00007-01.

This document is protected by copyright and distributed under licenses restricting its use, copying, distribution, and decompilation. No part of this document may be reproduced in any form by any means without prior written authorization of BLADE Network Technologies, Inc. Documentation is provided “as is” without warranty of any kind, either express or implied, including any kind of implied or express warranty of non-infringement or the implied warranties of merchantability or fitness for a particular purpose.

U.S. Government End Users: This document is provided with a “commercial item” as defined by FAR 2.101 (Oct. 1995) and contains “commercial technical data” and “commercial software documentation” as those terms are used in FAR 12.211-12.212 (Oct. 1995). Government End Users are authorized to use this documentation only in accordance with those rights and restrictions set forth herein, consistent with FAR 12.211- 12.212 (Oct. 1995), DFARS 227.7202 (JUN 1995) and DFARS 252.227-7015 (Nov. 1995).

BLADE Network Technologies, Inc. reserves the right to change any products described herein at any time, and without notice. BLADE Network Technologies, Inc. assumes no responsibility or liability arising from the use of products described herein, except as expressly agreed to in writing by BLADE Network Technologies, Inc. The use and purchase of this product does not convey a license under any patent rights, trademark rights, or any other intellectual property rights of BLADE Network Technologies, Inc.

BLADE Network Technologies, the BLADE logo, BLADEHarmony, BNT, NMotion, RackSwitch, Rackonomics, RackSwitch Solution Partner, ServerMobility, SmartConnect and VMready are trademarks of BLADE Network Technologies. All other names or marks are property of their respective owners.

Originated in the USA.

# Contents

---

## **Preface ■ 5**

Who Should Use This Book ■ 5

Related Documentation ■ 5

How to Get Help ■ 6

## **Chapter 1: RackSwitch G8000 Description and Specifications ■ 7**

RackSwitch G8000 Features ■ 7

Switch Components ■ 9

    Hardware Options ■ 9

    Switch Unit ■ 9

    Switch Ports ■ 13

    10 Gigabit Ethernet Port Expansion Slots ■ 15

    Switch LEDs ■ 16

    Optional Uplink Modules ■ 18

Technical Specifications ■ 19

    Physical Characteristics ■ 19

    Environmental Specifications ■ 19

    Power Specifications ■ 20

Ordering Information ■ 21

## **Chapter 2: Installing the RackSwitch G8000 ■ 23**

Required Tools ■ 23

Package Contents ■ 23

Environmental Requirements ■ 24

    Preventing Electric Shock ■ 24

    Preventing Electrostatic Discharge ■ 25

Installing the RackSwitch G8000 in a Standard Equipment Rack ■ 26

Installing the RackSwitch G8000 in an iDataPlex Rack ■ 28

Installing the RackSwitch G8000 in a 4-post Rack ■ 31

Initializing the RackSwitch G8000 ■ 34

    Default Configuration ■ 35

    Configuring an IP Interface ■ 35

Using the Boot Management Menu ■ 37

Installing an Optional Uplink Module ■ 38

- Installing an SFP/SFP+ Transceiver ■ 40
  - SFP Optical Transceiver ■ 40
  - SFP Copper Transceiver ■ 41
  - SFP+ Optical Transceiver ■ 42
- Troubleshooting ■ 43
  - System LEDs Do Not Light ■ 43
  - Port link LED Does Not Light ■ 43
  - Temperature Sensor Warning ■ 43
  - Switch Does Not Initialize (Boot) ■ 44
- Appendix A: Safety and Compliance Statements ■ 45**
  - Safety Messages ■ 45
  - Compliance Statements ■ 50

# Preface

---

This *Installation Guide* provides information and instructions to install a BLADE Network Technologies RackSwitch G8000. For information about configuration and management of the switch, refer to your *Command Reference* and the product release notes.

## Who Should Use This Book

---

This *Installation Guide* is intended for network installers and system administrators engaged in configuring and maintaining a network. It assumes that you are familiar with your RackSwitch G8000, your Web browser, Ethernet concepts, IP addressing, the IEEE 802.1D Spanning Tree Protocol, and SNMP configuration parameters.

## Related Documentation

---

For documentation about configuring your switch, see the RackSwitch G8000 *Application Guide* and *Command Reference*.

For details about the switch information, statistics, and configuration parameters, see the RackSwitch G8000 *Command Reference*.

## How to Get Help

---

If you need help, service, or technical assistance, call Blade Network Technologies Technical Support:

US toll free calls: 1-800-414-5268

International calls: 1-408-834-7871

You also can visit our web site at the following address:

`http://www.bladenetwork.net`

Click the **Support** tab.

The warranty card received with your product provides details for contacting a customer support representative. If you are unable to locate this information, please contact your reseller. Before you call, prepare the following information:

- Serial number of the switch unit
- Software release version number
- Brief description of the problem and the steps you have already taken
- Technical support dump information (`# show tech-support`)

---

**Note** – In case of any suspected hardware related defect, immediately call the BLADE support line to get the issue resolved. There are no field serviceable parts inside the enclosure and tampering with internal components in an attempt to diagnose hardware or fix defects will void the warranty and the product will be repaired at the customer's expense.

---

## CHAPTER 1

# RackSwitch G8000 Description and Specifications

---

The RackSwitch G8000 is a rackable aggregation switch with unmatched line-rate Layer 2/3 performance. The G8000 uses a wire-speed, non-blocking switching fabric that provides simultaneous wire-speed transport of multiple packets at low latency on all ports.

The G8000 contains forty-eight 1GbE ports and up to four optional 10GbE ports. The Gigabit Ethernet ports are comprised of forty-four 10/100/1000BaseT Ethernet ports and four Small Form-factor, Pluggable (SFP) slots. The SFP slots can be populated with optical or copper transceivers. The four optional 10GbE ports are comprised of one or two dual-port uplink modules (SFP+ or CX4).

This 1U switch is rack mountable in either the horizontal or vertical direction, depending on your application.

You can manage the switch through the console port, or through a network connection using Telnet, a Web browser-based interface, or SNMP-based network management software.

## RackSwitch G8000 Features

---

This section provides an overview of RackSwitch G8000 features.

### Performance

- 176 Gbps throughput (full duplex), non-blocking switching architecture
- 100% line rate
- Deterministic port-to-port latency under 3 microseconds with 64B packets

### Management Features

- Clients
  - Industry standard command-line interface (ISCLI)
  - Browser-based Interface (BBI)
  - BladeHarmony Manager

- Protocols
  - SNMP v1, v2, v3
  - Remote Monitoring (RMON)
  - Network Time Protocol (NTP) support
  - DHCP
- Software upgrades
  - Dual software images
  - Upgrade via serial, browser, or TFTP

### Software Features

- Security
  - Secure interface login & password
  - RADIUS and TACACS+
  - SSH v1, v2
  - HTTPS Secure Browser-based interface
  - Wire-speed filtering with Access Control Lists (ACLs)
- Layer 2
  - 1024 VLANs (802.1Q), including Private VLANs
  - Multi-link trunking, compatible with Cisco EtherChannel
  - LACP (IEEE 802.3ad)
  - Spanning Tree (802.1D), Multiple Spanning Tree (802.1s), Rapid Spanning Tree (802.1w), with Fast Uplink Convergence
  - 16K forwarding database entries
- Layer 3
  - Dynamic routing
    - RIP v1, v2
    - OSPF
    - BGP
  - 128 configurable interfaces (static or DHCP)
  - DHCP Relay
  - IP forwarding
  - IGMP Snooping v1, v2, v3
  - 4K ARP entries
  - IPv6 host management
- Quality of Service
  - 802.1p priority queues
  - Differentiated Services Code Point (DSCP) support
- Availability
  - Layer 2 Failover
  - VRRP

# Switch Components

---

This section describes the RackSwitch G8000 hardware components.

## Hardware Options

The following list provides an overview of G8000 hardware:

- Switch unit
- Mounting hardware
  - Standard rack mounting brackets and screws
  - iDataPlex rack mounting brackets and screws
  - 4-post rack mounting brackets and screws
- Optional uplink modules (not included with switch unit)
  - SFP+ uplink module (2 ports)
  - CX4 uplink module (2 ports)

## Switch Unit

The RackSwitch G8000 switch unit is a 1U rack-mountable Gigabit Ethernet switch. You can mount the G8000 in either the horizontal or vertical direction.

The RackSwitch G8000 allows for flexible mounting of the switch, as follows:

- RackSwitch G8000F provides front-to-rear airflow.
- RackSwitch G8000R provides rear-to-front airflow.
- DC powered RackSwitch G8000R provides front-to-rear airflow.

## Ports

The switch unit contains forty-eight 1GbE ports, as follows:

- Forty-four 10/100/1000BaseT ports (RJ-45)
- Four SFP slots

The G8000 includes two port expansion slots for dual-port, 10GbE uplink modules with SFP+ or CX4 transceivers. One slot is located on the front panel, and one slot is located on the rear panel.

**Figure 1** RackSwitch G8000 Front Panel

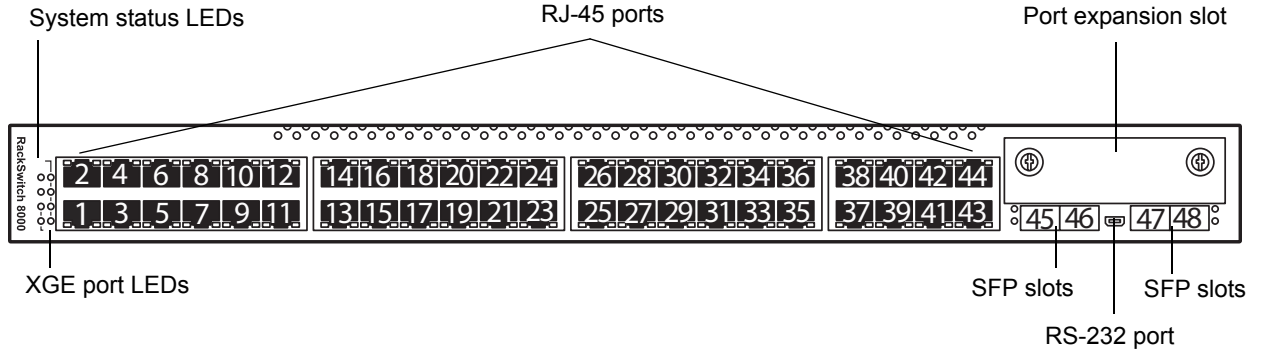

**Figure 2** RackSwitch G8000 Rear Panel

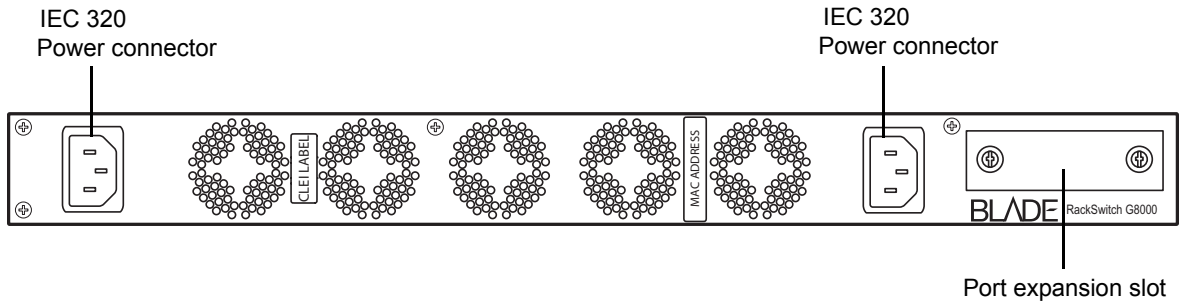

**Figure 3** RackSwitch DC G8000 Rear Panel

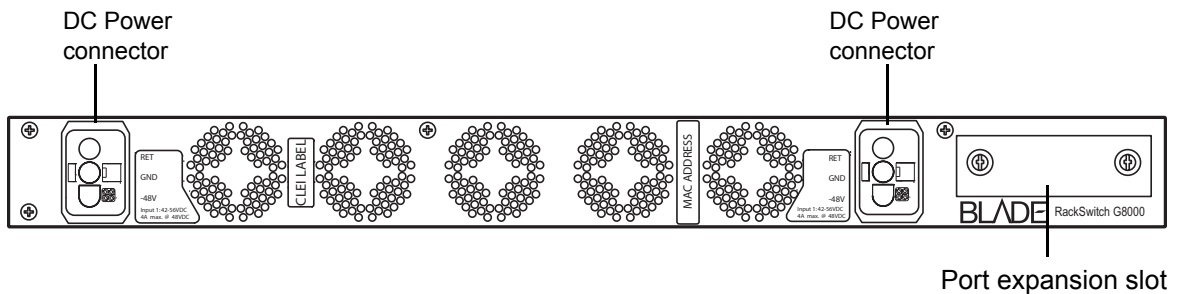

## Fans

Five internal fans cool the switch unit. If an individual fan fails, the other fans continue to run, and the switch unit continues to operate normally. Fans are not customer replaceable.

Fan operation and internal temperatures are monitored. If the air temperature exceeds a desired threshold, the environmental monitor displays warning messages.

---

**Note** – If a fan fails, the maximum operating temperature drops from +40°C to +35°C.

---

The Fan LED blinks if there is a failure of one or more fans.

## AC Power Supply

The G8000 has two redundant 150W AC power supplies. Each internal power supply has an individual IEC 320 power connector on the rear panel. The power cord attaches to a universal grounded AC power source.



---

**Caution**—To reduce the risk of electric shock, use only power cords that have a grounding path, and always connect the power cord to a properly grounded power outlet.

---

Each power supply can be connected to a separate AC circuit to mitigate the risk of down time during a power failure. When used in a redundant configuration, the dual power supplies have a load-sharing capability that allows each supply to operate at approximately 50 percent of full load. Using redundant power can minimize the power disruption during a power supply failure and extend the expected lifetime of each supply by operating normally in a conservative power mode.

There is no power switch on the G8000; the switch unit powers up when power is supplied through the power cord(s).

The Power Supply LED indicates the status of the power supplies. The LED blinks when only one power cord is connected, and lights steady when both power cords are connected.

## DC Power Supply

The DC Powered G8000 has two redundant 160W DC-DC power supplies, operating from 42V to 60V. Each internal power supply has a DC filter input on the rear panel. The DC power sources are connected to the G8000 via the mating connector cable assemblies provided. One end of the cable is connected to the G8000 and the three DC-input leads connect the DC-input power supply to the site power source. The pigtail end of the cable is color coded, as follows:

- Black: Negative (-48V)
- Red: Positive (return)
- Green: Ground



---

**Warning**—Only trained and qualified personnel can connect this equipment to the site power source.

---

Each power supply can be connected to a separate DC power source to mitigate the risk of down time during a power failure. When used in a redundant configuration, the dual power supplies have a load-sharing capability that allows each supply to operate at approximately 50 percent of full load. Using redundant power can minimize the power disruption during a power supply failure and extend the expected lifetime of each supply by operating normally in a conservative power mode.

There is no power switch on the G8000; the switch unit powers up when power is supplied through the DC power source.

The Power Supply LED indicates the status of the power supplies. The LED blinks when only one DC power source is connected, and lights steady when both DC power sources are connected.

## Switch Ports

The RackSwitch G8000 switch ports and port options are described below.

### 10/100/1000Base-T Ports

44 10/100/1000BaseT ports (RJ-45) are located on the front panel. In-line management and Control Plane Stacking are supported by using one or more of the RJ-45 ports for management.

The G8000 is designed to accept most standard 10/100/1000Base-T (category 5) cables.

The following table describes the RJ-45 connector pin assignments:

**Table 1** RJ-45 Port Pin Assignments

Pin number	Signal	Description
1	BI DA+	Bi-directional data pair A positive
2	BI DA-	Bi-directional data pair A negative
3	BI DB+	Bi-directional data pair B positive
4	BI DC+	Bi-directional data pair C positive
5	BI DC-	Bi-directional data pair C negative
6	BI DB-	Bi-directional data pair B negative
7	BI DD+	Bi-directional data pair D positive
8	BI DD-	Bi-directional data pair D negative

### SFP Slots

Four 1Gbps Small Form-factor Pluggable (SFP) slots are located on the front panel. These slots accept approved optical or copper SFP transceivers. SFP transceivers are not included with the G8000 switch unit.

The following SFP transceivers are available from Blade Network Technologies:

**Table 2** Recommended SFP Transceivers

Part number	Description
BN-CKM-S-T	SFP 1000Base-T Copper Transceiver
BN-CKM-S-SX	SFP 1000Base-SX Short Range Fiber Transceiver
BN-CKM-S-LX	SFP 1000BASE-LX Long Range Fiber Transceiver

## Console Port

The RS-232 (mini-USB) serial console port is located on the front panel. An external cable is required to convert to a D9 connector. The following table describes the pinouts for the mini-USB port:

**Table 3** Console Port Pin Assignments

Pin number	Function
Pin 1	No connect
Pin 2	RS232_SIN
Pin 3	RS232_SOUT
Pin 4	No connect
Pin 5	Ground

The following table describes the wiring of the console cable:

**Table 4** Console Cable Wiring

D9 Pin number	Wire	Mini-USB Pin number
Pin 2	Black	Pin 3
Pin 3	White	Pin 2
Pin 5	Green	Pin 5
Pin 1	D9 Pins 1, 4, and 6 are connected	
Pin 4		
Pin 6		
Pin 7	D9 pin 7 is connected to D9 pin 8	
Pin 8		
Shell	Braid	Shell

## 10 Gigabit Ethernet Port Expansion Slots

The G8000 switch unit includes two port expansion slots, one on the front panel and one on the rear panel. Each expansion slot accepts a dual-port 10GbE (XGE) uplink module for either CX4 or SFP+.

You can add one or two XGE uplink modules, as follows:

### SFP+ Uplink Module

Up to four 10Gbps Small Form-factor Pluggable (SFP+) slots can be installed on the G8000. These slots accept approved optical SFP+ transceivers. SFP+ transceivers are not included with the G8000 switch unit or with the port uplink modules.

The following SFP+ transceivers are available from Blade Network Technologies: SFP+ 10GBase-ST Short Range Optical Fiber Transceiver

**Table 5** Recommended SFP+ Transceiver

Part number	Description
BN-CKM-SP-SR	SFP+ 10GBase-SR Short Range Optical Fiber Transceiver
BN-CKM-SP-LR	SFP+ 10GBase-LR Long Range Optical Fiber Transceiver

### CX4 Uplink Module

Up to four CX4 ports can be installed on the G8000. These ports provide CX4 connectivity between the G8000 and copper 10GbE CX4 network devices. The CX4 ports support link spans up to 15 meters on appropriate CX4-grade copper cables.

The CX4 ports provide powered CX4 automatically. The port detects when a powered CX4 device is connected, and sends power to the device.

The G8000 is designed to accept most standard 10GbE CX4 cables.



---

**Note –** Do not use InfiniBand CX4 cables with the G8000. Although InfiniBand cables have the same CX4 connectors as 10GBase-CX4 cables, InfiniBand cables do not adhere to the same standard as 10GBase-CX4 cables.

---

## Switch LEDs

Two LED stacks provide system status and port link status. The system LEDs are described in the following table:

	Power supplies and AC or DC power input status
	Fans status
<b>MB</b>	Stacking master indicator
<b>MS</b>	Stacking member indicator

The following table describes the system LED indications:

**Table 6** System LEDs Status

Function	Power Supply	Fan	Master	Member	XGE Port
Total Power Failure	Off	Off	Off	Off	Off
Service Required	Blink Green	Blink Green	Blink Green	Blink Green	Blink Green
Power Supplies OK	Solid Green	N/A	N/A	N/A	N/A
Power Supply Failure	Blink Green	N/A	N/A	N/A	N/A
Fans OK	N/A	Solid Green	N/A	N/A	N/A
Fan Failure	N/A	Blink Green	N/A	N/A	N/A
Stack Master	N/A	N/A	On	Off	N/A
Stack Backup/Member	N/A	N/A	Off	On	N/A
Stack Error	N/A	N/A	On	On	N/A
Non-Stack Member	N/A	N/A	Off	Off	N/A

## RJ-45 LEDs

Status LEDs for the RJ-45 ports are described in the following table.

**Table 7** RJ45 LEDs Status

LED	Solid Green	Blink Green	Off
Link	Valid Link	Activity	No Link
Speed	100/1000Mbps	N/A	10Mbps

## SFP LEDs

Status LEDs for the SFP ports are described in the following table.

**Table 8** SFP LEDs Status

LED	Solid Green	Blink Green	Off
Port Link	Valid Link	N/A	No Link

## XGE Link LEDs

Figure 4 highlights the system LEDs and XGE port LEDs.

**Figure 4** System Status LEDs and XGE Port LEDs

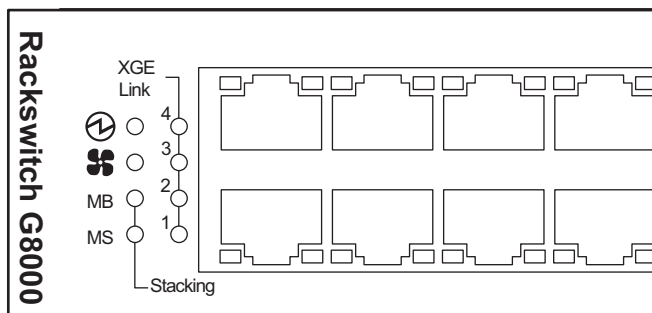

XGE Link LEDs provide the link status for ports on each of the uplink modules, if applicable. Optional XGE ports one (port 49) and two (port 50) are located in the uplink module on the front panel. Optional XGE ports three (port 51) and four (port 52) are located in the uplink module on the rear panel.

**Table 9** XGE Module LEDs Status

LED	Solid Green	Blink Green	Off
Port Link	Valid Link	N/A	No Link

## Optional Uplink Modules

You can install up to two port uplink modules, one on the front panel and one on the rear panel. Each expansion slot accepts either a SFP+ Uplink Module or a CX4 Uplink Module, as described below:

### SFP+ Uplink Module

The SFP+ Uplink Module contains two 10 Gigabit Ethernet optical transceiver slots, as shown below:

**Figure 5** SFP+ Uplink Module

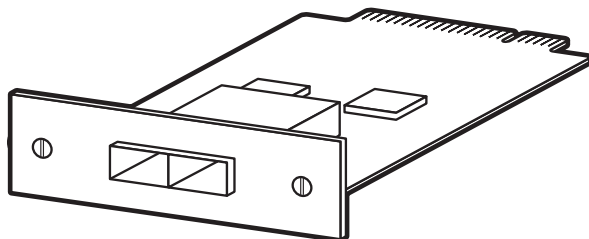

The SFP+ Uplink Module provides 10GbE connectivity over fiber cable. The SFP+ slots require approved SFP+ optical transceivers.

### CX4 Uplink Module

The CX4 Uplink Module is a 10 Gigabit Ethernet CX4 short range module. It contains two 10GbE CX4 ports, as shown below:

**Figure 6** CX4 Uplink Module

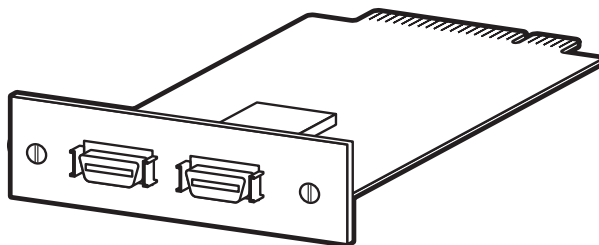

The CX4 Uplink Module provides CX4 connectivity between the G8000 and copper 10GbE CX4 network devices. The CX4 ports support link spans up to 15 meters on appropriate CX4-grade copper cables.

# Technical Specifications

## Physical Characteristics

Physical characteristics of the RackSwitch G8000 switch unit are listed in the following table.

**Table 10** Physical characteristics

Specification	G8000F	G8000R
Dimensions (H x W x D)	1.73 x 17.3 x 15.0 in. 4.4 x 43.9 x 38.1 cm.	1.73 x 17.3 x 15.0 in. 4.4 x 43.9 x 38.1 cm.
Weight	5.5 kg.	5.5 kg.
Airflow	Front-to-rear	Rear-to-front

## Environmental Specifications

Environmental specifications for the RackSwitch G8000 switch unit are listed in the following table.

**Table 11** Environmental specifications

Specification	Measurement
Temperature, ambient operating	0°C to +40°C
Temperature (fan failure), operating	0°C to +35°C
Temperature, storage	-40°C to +85°C
Relative humidity (non-condensing), operating	10 to 90%
Relative humidity (non-condensing), storage	10 to 90%
Altitude, operating	3,050 m (10,000 feet)
Altitude, storage	12,190 m (40,000 feet)
Acoustic noise	Less than 65dB
Heat dissipation	520 BTU/hour

## Power Specifications

Power specifications for the RackSwitch G8000F/G8000R switch unit are listed in [Table 12](#) and [Table 13](#).

**Table 12** AC Power Specifications

Specification	Measurement
Number of power supplies	2 (1+1 redundant)
AC-input frequency (universal)	50-60 Hz
AC-input voltage (universal)	100-240 VAC
AC-input current	1.5A (RMS) @ 120V 0.7A (RMS) @ 230V
AC-input fuse	2A, 250 VAC (time lag)
Power supply output power	150W each
System power dissipation	120W typical
DC-Output voltage	12V nominal
DC-Output current	10A (typical)

**Table 13** DC Power Specifications

Specification	Measurement
Number of power supplies	2 (1+1 redundant)
Input Voltage	42VDC-60VDC 48VDC Nominal
RMS Input Current	3.3 A Maximum
Power supply output power	160W

## Ordering Information

The following table lists the parts that you can order for the RackSwitch G8000 product family.

**Table 14** RackSwitch G8000 Ordering Information

Part number	Description
<b>Switch</b>	
BN-8000F-BDL	RackSwitch G8000F 48-port GbE Switch (front-to-rear airflow)
BN-8000R-BDL	RackSwitch G8000R 48-port GbE Switch (rear-to-front airflow)
BN-8000F-DC-BDL	DC Powered RackSwitch G8000R 48-port GbE Switch (front-to-rear airflow)
<b>Uplink Modules</b>	
BN-8000-XGE-CX4	Dual Port CX4 Uplink Module
BN-8000-XGE-SFPP	Dual Port SFP+ Uplink Module
<b>Pluggable Optics</b>	
BN-CKM-S-T	SFP 1000Base-T Copper Transceiver
BN-CKM-S-SX	SFP 1000Base-SX Short Range Fiber Transceiver
BN-CKM-S-LX	SFP 1000BASE-LX Long Range Fiber Transceiver
BN-CKM-SP-SR	SFP+ 10GBase-SR Short Range Transceiver
BN-CKM-SP-LR	SFP+ 10GBase-LR Long Range Optical Fiber Transceiver
<b>Rack Mounting Kits</b>	
BN-MNT-EARS	RackSwitch 19" EIA 2-Post Rack Mounting Kit
BN-MNT-HZ-RLS	RackSwitch 19" EIA 4-Post Rack Mounting Kit
BN-MNT-DPX-RLS	RackSwitch iDataPlex Rack Mounting Kit



## CHAPTER 2

# Installing the RackSwitch G8000

---

This chapter describes how to install and initialize the RackSwitch G8000.

## Required Tools

---

You need the following tools or equipment to successfully accomplish the installation procedures in this document:

- Standard flat-blade screwdriver
- #2 Phillips screwdriver
- Electrostatic discharge wrist strap

## Package Contents

---

The basic RackSwitch G8000 package contains the following items:

- G8000 switch unit (one of the following):
  - G8000F (front-to-rear airflow)
  - G8000R (rear-to-front airflow)
- Standard rack mount kit
  - Two brackets
  - Screws to attach brackets to the switch unit
  - Screws to attach the switch unit to the equipment rack
- Mini-USB serial cable
- Two AC or DC power cords

## Environmental Requirements

---

This section describes the basic environmental requirements for the RackSwitch G8000. Make sure the location where you install the switch meets the following requirements:

- Install the switch unit in a dry, clean, well-ventilated area.
- Provide adequate space on all sides of the switch unit, to ensure proper air flow.
- Make sure that an adequate grounded power supply is within reach of the switch unit.
- Make sure that twisted-pair cable is routed away from power lines, fluorescent lighting fixtures and other sources of electrical interference.

## Preventing Electric Shock

This product does not contain any user-serviceable parts. Do not remove the cover of this device.

The AC G8000 is designed to work with single-phase power systems that have a grounded neutral conductor. To reduce the risk of electric shock, always plug the power cord into a grounded power outlet.



---

**Warning**—Electrical current from power, telephone, and communication cables is hazardous. To avoid a shock hazard:

- Do not connect or disconnect any cables or perform installation, maintenance, or reconfiguration of this product during an electrical storm.
  - Connect the power supply only to a properly wired and grounded power source.
  - Connect to properly wired outlets any equipment that will be attached to this product.
  - When possible, use one hand only to connect or disconnect signal cables.
  - Never turn on any equipment when there is evidence of fire, water, or structural damage.
  - Disconnect the power supply, telecommunications systems, networks, and modems before you open the device covers, unless instructed otherwise in the installation and configuration procedures.
  - Disconnect the power supply before installing, uninstalling, or moving this product.
-

## Preventing Electrostatic Discharge

Electrostatic discharge (ESD) is a discharge of stored static electricity that can damage equipment and impair electrical circuitry. ESD can cause intermittent or complete equipment failures.

Use the following guidelines to prevent ESD damage while you install and work with the G8000 and optional equipment:

- Use anti-static wrist straps. Adjust the strap to provide good skin contact.
- Properly ground work surfaces and equipment racks for protection against electrostatic discharge.
- Avoid contact between equipment and clothing. An anti-static wrist or ankle strap protects the equipment from ESD voltages on the body; ESD voltages on clothing also can cause damage.
- Do not touch connector pins.

# Installing the RackSwitch G8000 in a Standard Equipment Rack

This section describes how to install the RackSwitch G8000 in a standard 19-inch equipment rack. For information about mounting the G8000 in other rack types, refer to the following sections:

- “Installing the RackSwitch G8000 in an iDataPlex Rack” on page 28
- “Installing the RackSwitch G8000 in a 4-post Rack” on page 31

The following table lists the parts included in the standard mounting kit.

**Table 15** Standard Mounting Kit Parts

Item number	Part number	Description	Quantity
1	BMM-00056-00	Bracket	2
2	BMC-00046-00	M6 screws, washers, and clip nuts	4
3	BMC-00049-00	M4 screws	8



**Caution**—Do not stack other devices on top of the switch unit in the rack. The mounting brackets cannot support multiple devices. Use mounting brackets to secure each device to the rack.

Perform the following steps to mount the RackSwitch G8000.

1. Use the M4 screws to attach a mounting bracket to each side of the switch. Torque the screws to approximately 30 inch-pounds (3.5 Nm).

**Figure 7** Attaching the Mounting Brackets

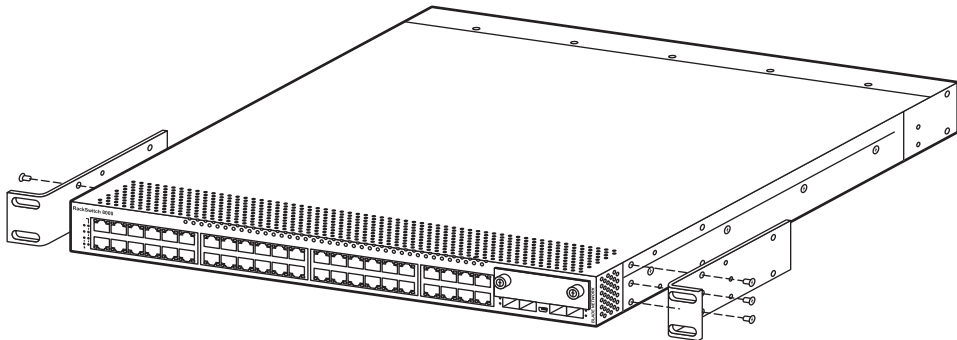

2. Slide the switch into the rack as illustrated.

**Figure 8** Rack-mounting the Switch Unit

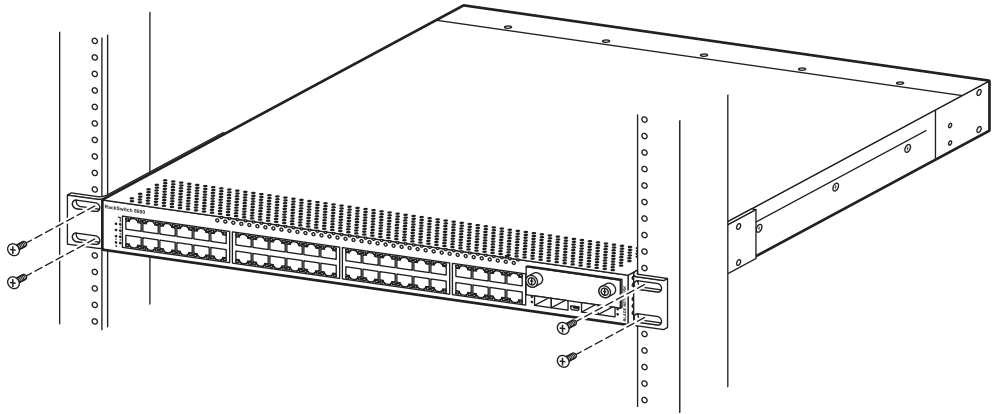

3. Use M6 screws, washers, and clip nuts to secure the switch unit to the rack. Torque the screws to approximately 70 inch-pounds (8 Nm).

## Installing the RackSwitch G8000 in an iDataPlex Rack

This section provides general information about installing the RackSwitch G8000 in an IBM iDataPlex rack. The iDataPlex mounting kit allows the switch to be mounted either vertically or horizontally. For information about mounting the G8000 in other rack types, refer to the following sections:

- [“Installing the RackSwitch G8000 in a Standard Equipment Rack” on page 26](#)
- [“Installing the RackSwitch G8000 in a 4-post Rack” on page 31](#)

The mounting kit is ordered separately. The following table lists the parts included in the iDataPlex mounting kit.

**Table 16** BN-MNT-DPX-RLS iDataPlex Rack Mount Kit

Item number	Part number	Description	Quantity
1	BMM-00098-00	Rear brackets	2
2	BMM-00056-00	Front brackets	2
3	BMM-00066-00	Alignment plate	2
4	BMC-00056-00	M6 screws	8
4	BMC-00015-01	M6 locking washers	8
4	BMC-00069-00	M6 clip nuts	8
5	BMC-00049-00	M4 screws	16

Perform the following steps to mount the RackSwitch G8000 into an iDataPlex rack.

1. Use the M4 screws to attach front and rear mounting brackets to each side of the switch unit. Torque the screws to approximately 30 inch-pounds (3.5 Nm).

**Figure 9** Attaching the iDataPlex mounting brackets

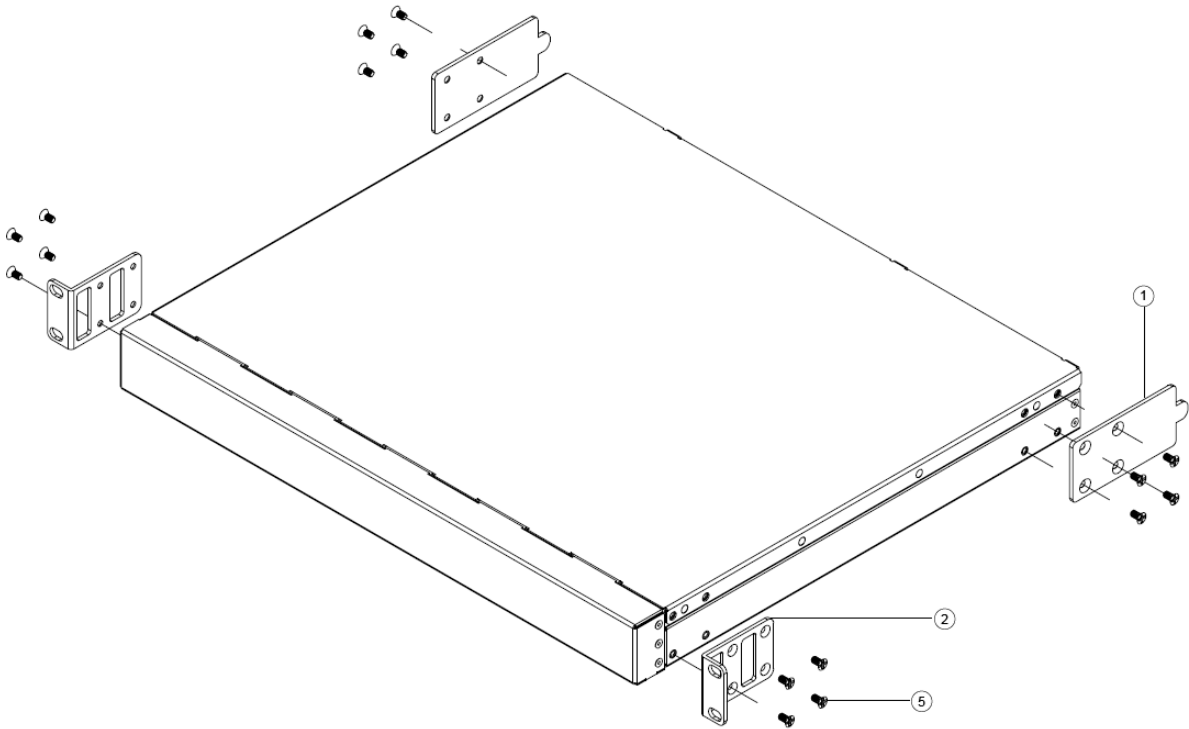

2. M6 screws, washers, and clip nuts are used to attach the alignment plate. Torque the screws to approximately 30 inch-pounds (3.5 Nm).

**Figure 10** Attaching the alignment plate

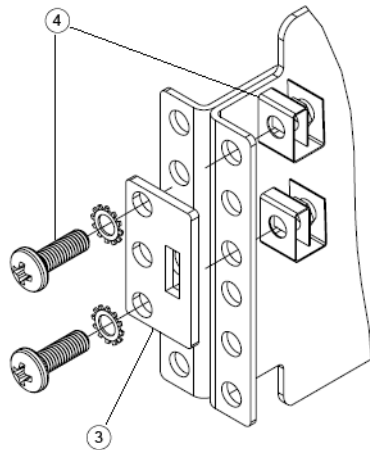

3. M6 screws, washers, and clip nuts are used to mount the switch unit into the rack. Torque the screws to approximately 30 inch-pounds (3.5 Nm).

**Figure 11** Rack-mounting the switch unit

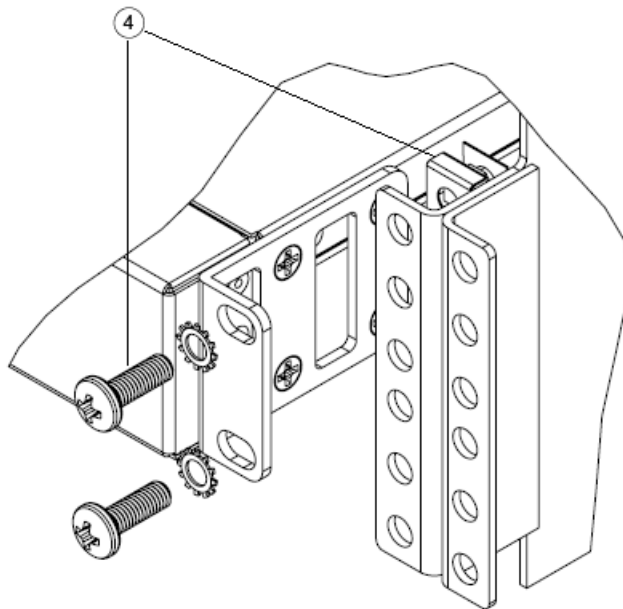

## Installing the RackSwitch G8000 in a 4-post Rack

This section provides general information about installing the RackSwitch G8000 in a 4-post rack, such as the IBM e1350. For information about mounting the G8000 in other rack types, refer to the following sections:

- [“Installing the RackSwitch G8000 in a Standard Equipment Rack” on page 26](#)
- [“Installing the RackSwitch G8000 in an iDataPlex Rack” on page 28](#)

The 4-post mounting kit is ordered separately. The following table lists the parts included in the 4-post mounting kit.

**Table 17** BN-MNT-HZ-RLS 4-Post Rack Mount Kit

Item number	Part number	Description	Quantity
1	BMM-00065-00	Left bracket	1
2	BMM-00067-00	Right bracket	1
3	BMM-00089-00	Filler plate	1
4	BMC-00056-00	M6 screws	12
4	BMC-00015-01	M6 locking washers	12
4	BMC-00069-00	M6 clip nuts	8
5	BMC-00049-00	M4 screws	16

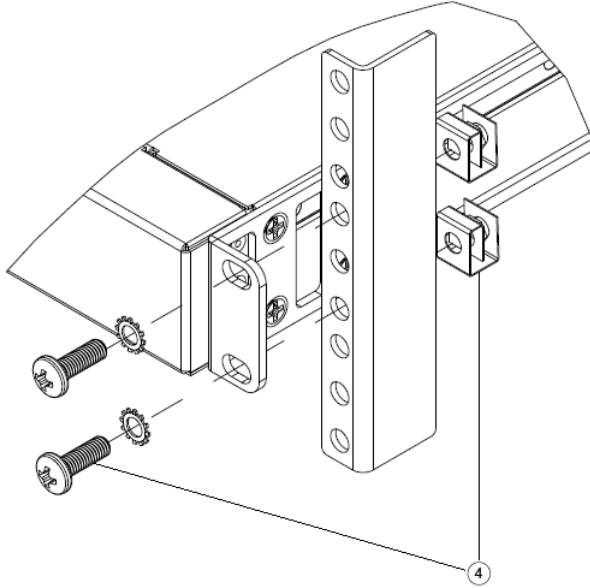

**Figure 13** Rack-mounting the switch unit

3. The rear filler plate is secured to the rack with M6 screws, washers, and clip nuts. Torque the screws to approximately 30 inch-pounds (3.5 Nm).

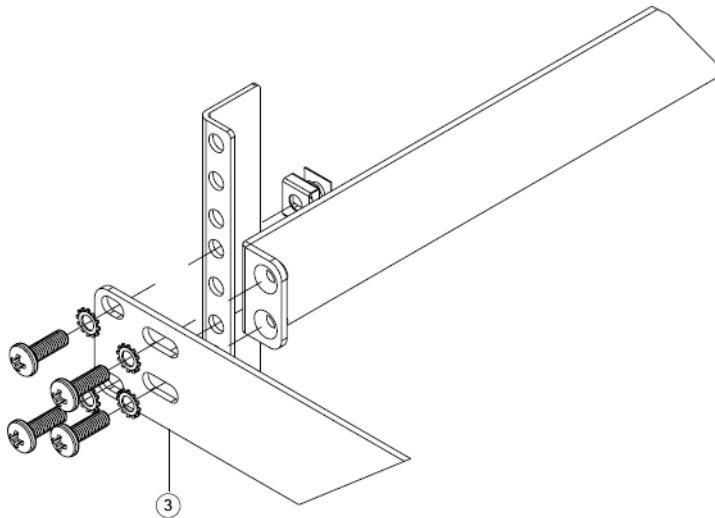
**Figure 14** Attaching the rear filler plate

## Initializing the RackSwitch G8000

---

When you supply power to the RackSwitch G8000, the switch initializes automatically.



**Caution**—The G8000 does not have a power switch. When you connect the switch to a suitable power source, the switch powers up immediately.

Disconnecting the switch from the power source is the only way to power down the G8000. Always provide the power source in a location that is quickly and safely accessible.

---

The following LEDs indicate the overall system status:

- Power Supply = Solid Green if both power cords are connected, blinking green if only one power cord is connected
- Fan = Solid Green if all fans are running, blinking green if there is a fan failure

Use the mini-USB console cable to connect the RS-232 serial port on the switch unit's front panel to a terminal or a PC running a terminal emulation program. You can access the command-line interface to perform initial configuration tasks.

The console port's terminal-emulation requirements are as follows:

- Default baud rate = 9,600 bps
- Character size = 8 characters
- Parity = none
- Stop bits = 1
- Data bits = 8
- Flow control = none

The switch performs initial self tests, and displays the `Password:` prompt, similar to the following screen:

```
Memory Test .....
Production Mode
PPCBoot 0.0.0.10 (new flash)
Memory Test (0x00) .....PASSED

...

Blade Network Technologies RS 8000

Jan 1 00:01:27 2008:
NOTICE-5:Interface Oper Status Indication - Port 7 State UP

Password:
```

At the `Password:` prompt, enter the switch password, and press `<Enter>`. The default password is **admin**.

## Default Configuration

The switch software contains default configuration files that are loaded at the factory. The default configuration is part of the software; it cannot be deleted or changed. The default settings allow the switch to perform basic functions with minimal effort by the system administrator.

## Configuring an IP Interface

To manage the switch using Telnet, SNMP, or a Web browser, you must configure an IP interface. Configure the following IP parameters:

- IP address
- Subnet mask
- Gateway address

1. Log on to the switch.
2. Enter IP interface mode.

```
RS G8000> enable  
RS G8000# configure terminal  
RS G8000 (config)# interface ip 1
```

3. Configure an IP interface, subnet mask, and VLAN assignment. Enable the interface.

```
RS G8000 (config-ip-if)# ip address 10.10.10.2 (example IP address)  
RS G8000 (config-ip-if)# ip netmask 255.255.255.0  
RS G8000 (config-ip-if)# vlan 1  
RS G8000 (config-ip-if)# enable  
RS G8000 (config-ip-if)# exit
```

4. Configure the default gateway. Enable the gateway.

```
RS G8000 (config)# ip gateway 1 address 10.10.10.1 (example gateway address)  
RS G8000 (config)# ip gateway 1 enable
```

Once you configure the IP address for your switch and you have an existing network connection, you can use the Telnet program from an external management station to access and control the switch. The management station and your switch must be on the same IP subnet.

The G8000 supports a command-line interface (CLI) that you can use to configure and control the switch over the network using the Telnet program. You can use the CLI to perform many basic network management functions. In addition, you can configure the switch for management using an SNMP-based network management system or a Web browser.

For more information about using the CLI, refer to the RackSwitch G8000 *Command Reference*.

## Using the Boot Management Menu

---

The Boot Management menu allows you to switch the software image, reset the switch to factory defaults, or to recover from a failed software download.

You can interrupt the boot process and enter the Boot Management menu from the serial console port. When the system displays Memory Test, press <Shift B>. The Boot Management menu appears.

```
Resetting the System ...
Memory Test .....

Boot Management Menu
1 - Change booting image
2 - Change configuration block
3 - Xmodem download
4 - Exit

Please choose your menu option: 1
Current boot image is 1. Enter image to boot: 1 or 2: 2
Booting from image 2
```

The Boot Management menu allows you to perform the following actions:

- To change the boot image, press 1 and follow the screen prompts.
- To change the configuration block, press 2, and follow the screen prompts.
- To perform an Xmodem download, press 3 and follow the screen prompts.
- To exit the Boot Management menu, press 4. The boot process continues.

## Installing an Optional Uplink Module

The G8000 supports the following optional dual-port uplink modules:

- SFP+ Uplink Module
- CX4 Uplink Module

The G8000 contains one port expansion slot on the front panel, and one port expansion slot on the rear panel. Each expansion slot can accept either a SFP+ or a CX4 uplink module.

---

**Note** – The optional uplink modules are not hot-swappable.

---

To install an uplink module, perform the following steps:

1. Disconnect the power cord from the power supply.
2. Loosen the retainer screws and remove the blank metal plate from the appropriate slot.
3. Remove the port option module from the anti-static shielded bag.
4. Slide the module into the card guides in the open slot and gently push it all the way into the slot, so that it firmly engages with the connector.

Each port option module has a mechanical guide key to prevent you from inserting the module incorrectly.

---

**Note** – You might need to raise the module as you slide it into the module slot, to clear SFP transceivers installed below the slot.

---

**Figure 15** Installing an Uplink Module

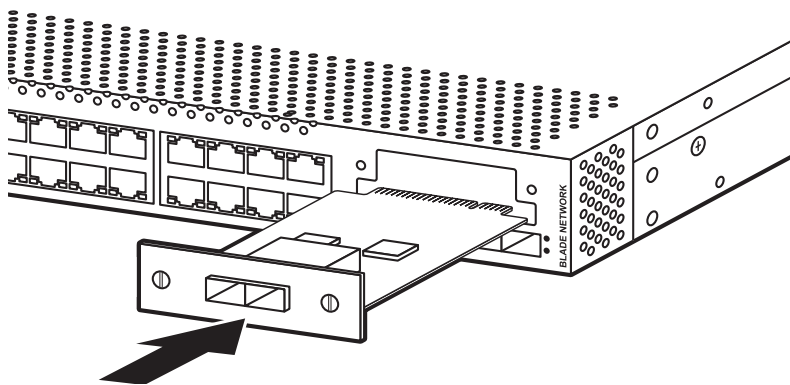

5. Tighten the retainer screws to secure the module.

6. When a cable is connected and a valid link is established, the XGE Link LEDs on the switch's front panel light up, as follows:

- XGE Link LEDs 1 and 2 correspond to module ports on the front panel, as shown below:

**Figure 16** Front Panel XGE Port Assignments

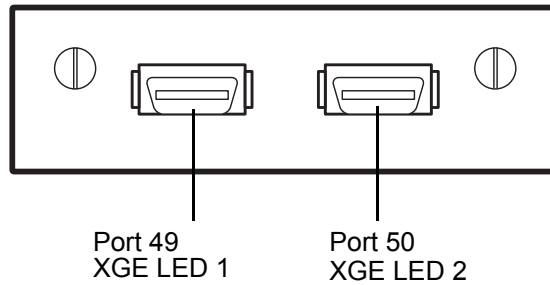

- XGE Link LEDs 3 and 4 correspond to module ports on the rear panel, as shown below:

**Figure 17** Rear Panel XGE Port Assignments

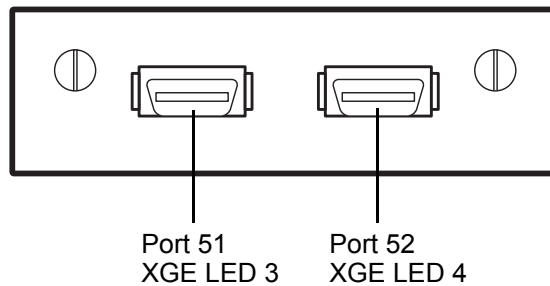

## Installing an SFP/SFP+ Transceiver

---

The RackSwitch G8000 supports the following Small Form Factor Pluggable (SFP) transceivers:

- Blade Network Technologies SFP 1000Base-T Copper Transceiver
- Blade Network Technologies SFP 1000Base-SX Short Range Optical Fiber Transceiver
- Blade Network Technologies SFP+ 10GBase-SR Short Range Optical Fiber Transceiver

### SFP Optical Transceiver

The SFP optical transceiver provides two fiber-optic cable connectors for connecting to external ports.



---

#### Caution—Class 1 Laser Product

- Do not look directly into a fiber-optic transceiver or into the ends of fiber-optic cables.
  - Fiber-optic transceivers and fiber-optic cable connected to a transceiver emit laser light that can damage your eyes.
  - Do not leave a fiber-optic transceiver uncovered except when inserting or removing cable.
  - The safety cap keeps the port clean and prevents accidental exposure to laser light.
  - Always inspect and clean the LC connector end faces before making any connections.
- 

Perform the following steps to install an SFP optical transceiver into a 1Gbps SFP slot on the G8000 switch unit.

---

**Note –** To avoid damage to the cable or the SFP transceiver, do not connect the fiber-optic cable before you install the transceiver.

---

1. Remove the safety cap and pull the locking lever into the down (unlocked) position.
2. Insert the transceiver into the port until it clicks into place. Use minimal pressure when you insert the transceiver into the slot. Do not use excessive force when you insert the transceiver; you can damage the transceiver or the SFP slot.

The transceiver has a mechanical guide key to prevent you from inserting the transceiver incorrectly.

3. Pull up the locking lever to lock the transceiver into place.
4. Connect the fiber-optic cable.

To remove a SFP optical transceiver, disconnect the fiber-optic cable, and pull down the locking lever to release the transceiver. After you remove the transceiver, replace the safety cap.

## SFP Copper Transceiver

The SFP copper transceiver provides an RJ-45 connector that accepts a standard 10/100/1000Base-T (category 5) cable.

Perform the following steps to install an SFP copper transceiver into a 1Gbps SFP slot on the G8000 switch unit.

---

**Note** – To avoid damage to the cable or the SFP transceiver, do not connect the cable before you install the transceiver.

---

1. Remove the safety cap and pull the locking lever into the down (unlocked) position.
2. Insert the transceiver into the port until it clicks into place. Use minimal pressure when you insert the transceiver into the slot. Do not use excessive force when you insert the transceiver; you can damage the transceiver or the SFP slot.

The transceiver has a mechanical guide key to prevent you from inserting the transceiver incorrectly.

3. Pull up the locking lever to lock the transceiver into place.
4. Connect the cable.

To remove a SFP copper transceiver, disconnect the cable, and pull down the locking lever to release the transceiver. After you remove the transceiver, replace the safety cap.

## SFP+ Optical Transceiver

The optional SFP+ Uplink Module accepts approved SFP+ transceivers. The SFP+ optical transceiver provides two fiber-optic cable connectors for connecting to external ports.



---

### Caution—Class 1 Laser Product

- Do not look directly into a fiber-optic transceiver or into the ends of fiber-optic cables.
  - Fiber-optic transceivers and fiber-optic cable connected to a transceiver emit laser light that can damage your eyes.
  - Do not leave a fiber-optic transceiver uncovered except when inserting or removing cable.
  - The safety cap keeps the port clean and prevents accidental exposure to laser light.
  - Always inspect and clean the LC connector end faces before making any connections.
- 

Perform the following steps to install an SFP+ optical transceiver into a slot on the SFP+ Uplink Module.

---

**Note –** To avoid damage to the cable or the transceiver, do not connect the fiber-optic cable before you install the transceiver.

---

1. Remove the safety cap and pull the locking lever into the down (unlocked) position.
2. Insert the transceiver into the port until it clicks into place. Use minimal pressure when you insert the transceiver into the slot. Do not use excessive force when you insert the transceiver; you can damage the transceiver or the SFP+ slot.

The transceiver has a mechanical guide key to prevent you from inserting the transceiver incorrectly.

3. Pull up the locking lever to lock the transceiver into place.
4. Connect the fiber-optic cable.

To remove a SFP+ optical transceiver, disconnect the fiber-optic cable, and pull down the locking lever to release the transceiver. After you remove the transceiver, replace the safety cap.

# Troubleshooting

---

This section contains basic troubleshooting information to help resolve problems that may occur during installation and operation of your switch. If you have problems accessing the switch or working with the software, refer to your RackSwitch G8000 *Command Reference*.

If you need additional technical assistance, refer to [“How to Get Help” on page 6](#).

## System LEDs Do Not Light

**Symptom:** The Power Supply and Fan LEDs do not light.

**Solution:** Check the power supply to make sure there is a proper connection to the power source. Verify that AC or DC power is available from the power source.

## Port link LED Does Not Light

**Symptom:** Port link LED does not light.

**Solution 1:** Check the port configuration in software (refer to your *Command Reference*). If the port is configured with a specific speed or duplex mode, check the other device to verify that it is set to the same configuration. If the switch port is set to autonegotiate, verify that the other device is set to autonegotiate.

**Solution 2:** Check the cables that connect the port to the other device. Make sure they are connected properly. Verify that you are using the correct cable type.

## Temperature Sensor Warning

**Symptom:** A temperature warning is displayed on the management console.

**Solution:** Make sure that the air circulation vents on the front, back, and sides of the switch are free from obstruction by cables, panels, rack frames, or other materials.

Make sure that all cooling fans inside the switch are running. The Fan LED blinks if there is a failure of one or more fans. The following command displays fan status:

```
show sys-info
```

If any fan stops during switch operation, contact Customer Support.

## Switch Does Not Initialize (Boot)

**Symptom:** All the switch LEDs stay on, and the command prompt does not appear on the console.

**Solution:** The operating system may have been damaged. Use the console port to perform a serial upgrade of the switch software. Refer to your *Command Reference*.

## APPENDIX A

# Safety and Compliance Statements

---

### Safety Messages

This section lists the safety messages that appear within this manual.

---



**Caution**—To reduce the risk of electric shock, use only power cords that have a grounding path, and always connect the power cord to a properly grounded power outlet.

**ATTENTION**—Pour réduire le risque de décharge électrique, employez seulement les cordons de secteur qui ont un chemin fondant, et reliez toujours le cordon de secteur à une sortie correctement au sol de puissance.

**PRECAUCIÓN**—Para reducir el riesgo de descarga eléctrica, utilice solamente los cables eléctricos que tienen una trayectoria que pone a tierra, y conecte siempre el cable eléctrico con un enchufe de energía correctamente puesto a tierra.

**VORSICHT**—Zu das Risiko des Elektroschocks verringern, benutzen Sie nur Netzanschlusskabel, das einen erdenweg haben, und schließen Sie immer das Netzanschlusskabel an einen richtig geerdeten Energienanschluß an.

---



**Caution**—Only trained and qualified personnel can connect this equipment to the site power source.

**ATTENTION**—Seulement le personnel qualifié et qualifié peut relier cet équipement à la source d'énergie d'emplacement.

**PRECAUCIÓN**—Solamente los personales entrenados y calificados pueden conectar este equipo con la fuente de energía del sitio.

**VORSICHT**—Nur ausgebildetes und qualifiziertes Personal kann diese Ausrüstung an die AufstellungsortEnergiequelle anschließen.

---



**Warning**—Electrical current from power, telephone, and communication cables is hazardous. To avoid a shock hazard:

- Do not connect or disconnect any cables or perform installation, maintenance, or reconfiguration of this product during an electrical storm.
  - Connect the power supply only to a properly wired and grounded power source.
  - Connect to properly wired outlets any equipment that will be attached to this product.
  - When possible, use one hand only to connect or disconnect signal cables.
  - Never turn on any equipment when there is evidence of fire, water, or structural damage.
  - Disconnect the power supply, telecommunications systems, networks, and modems before you open the device covers, unless instructed otherwise in the installation and configuration procedures.
  - Disconnect the power supply before installing, uninstalling, or moving this product.
- 



**Avertissement**—Le courant électrique des câbles d'alimentation, des câbles téléphonique et des câbles de communication est dangereux. Pour éviter tout risque de choc électrique:

- Ne branchez, ni ne débranchez aucun des câbles et ne procédez à aucune installation, modification ou reconfiguration pendant un orage électrique.
  - Branchez tous les câbles d'alimentation à une prise électrique correctement câblée et avec prise de terre.
  - Tout équipement interconnecté à ce produit doit lui aussi être branché à une prise de courant proprement installée.
  - Si possible, utilisez une main seulement pour brancher ou débrancher les câbles de signaux.
  - Ne mettez jamais en marche un équipement quand il y a évidence de feu, d'eau, ou de dommages structuraux.
  - Débranchez les câbles d'alimentation, les systèmes de télécommunications, les réseaux, et les modems attachés avant d'ouvrir les couvercles du dispositif, à moins d'instructions particulières notées dans les procédures d'installation et de configuration.
  - Débranchez les cordons d'alimentation avant d'installer, de désinstaller ou de déplacer ce produit.
-



**Advertencia**—La corriente eléctrica de la energía, del teléfono, y de los cables de la comunicación es peligrosa. Para evitar un peligro de la descarga eléctrica:

- No conecte ni desconecte ninguna cables o no realice la instalación, el mantenimiento, o la reconfiguración de este producto durante una tormenta eléctrica.
  - Conecte la fuente de alimentación solamente con una fuente de energía correctamente atada con alambre y puesta a tierra.
  - Conecte con los enchufes correctamente atados con alambre cualquier equipo que sea atado a este producto.
  - Cuando es posible, utilice una mano para conectar o para desconectar solamente los cables de señal.
  - Nunca gire cualquier equipo cuando hay evidencia del fuego, del agua, o del daño estructural.
  - Desconecte la fuente de alimentación, los sistemas de telecomunicaciones, las redes, y los módems antes de que usted abra las cubiertas del dispositivo, a menos que esté dado instrucciones de otra manera en los procedimientos de la instalación y de configuración.
  - Desconecte la fuente de alimentación antes de instalar, de desinstalar, o de mover este producto.
- 



**Warnung**—Der Strom aus Kraft, Telefon, Kabel-und Kommunikationstechnologien ist gefährlich. Um eine Stromschlaggefahr zu vermeiden:

- Schließen Sie oder trennen Sie keine Kabel oder führen Sie die keine Installation, Wartung oder Neukonfiguration des Produkts während eines Gewitters.
  - Schließen Sie das Netzteil nur an eine ordnungsgemäß geerdete und geerdete Stromquelle.
  - Verbinden Sie diesem Produkt nur an richtig verdrahtete Stecker.
  - Verwenden Sie nach Möglichkeit nur einer Hand zu verbinden oder trennen Signalleitungen.
  - Kein Gerät einschalten, wenn es Anzeichen für Feuer, Wasser, oder Bauschäden gibt.
  - Trennen Sie die Stromversorgung, Telekommunikation, Netzwerke und Modems, bevor Sie das Gerätedeckel offen, sofern nicht anders in der Installation und Konfiguration angewiesen ist.
  - Trennen Sie das Netzteil vor der Installation, Deinstallation oder Verschieben von diesem Produkt.
-



**Caution**—Do not stack other devices on top of the switch unit in the rack. The mounting brackets cannot support multiple devices. Use mounting brackets to secure each device to the rack.

**ATTENTION**—Ne posez aucun appareil supplémentaire sur le commutateur sans support additionnel. Les supports ne peuvent soutenir plusieurs appareils. Utilisez les supports métalliques pour fixer chaque appareil aux armatures de la baie.

**PRECAUCIÓN**—No apile otros dispositivos encima de la unidad del interruptor en el estante. Los soportes de montaje no pueden apoyar los dispositivos múltiples. Utilice los soportes de montaje para asegurar cada dispositivo al estante.

**VORSICHT**—Stellen Sie keine anderen Geräte auf dem Switch-Einheit im Rack. Die Halterungen können nicht mehrere Geräte aushalten. Montagehalterungen verwenden um jedes Gerät am Rack zu befestigen.

---



**Caution**—The G8000 does not have a power switch. When you connect the switch to a suitable power source, the switch powers up immediately. Disconnecting the switch from the power source is the only way to power down the G8000. Always provide the power source in a location that is quickly and safely accessible.

**ATTENTION**—Le G8000 ne dispose pas d'un interrupteur de marche/arrêt. Quand vous connectez le cordon d'alimentation à la prise secteur du courant alternatif, le commutateur s'allume immédiatement. La seule manière d'éteindre le commutateur est de débrancher les câbles d'alimentation. Assurez-vous de connecter le câble d'alimentation à une pris électrique facile d'accès et sans risques.

**PRECAUCIÓN**—El G8000 no tiene un interruptor. Cuando usted conecta el interruptor con una fuente de energía conveniente, las energías del interruptor para arriba inmediatamente. La desconexión el interruptor de la fuente de energía es la única manera de accionar abajo el G8000. Proporcione siempre la fuente de energía en una localización que esté rápidamente y con seguridad accesible.

**VORSICHT**—Der G8000 hat keinen Netzschalter. Wenn Sie eine es auf eine geeignete Energiequelle, schaltet es sofort ein. Das Trennen vom Stromversorgung ist die einzige Möglichkeit zum der G8000 auszuschalten. Immer die Stromversorgung an einem Ort verbringen, der schnell und sicher zugänglich ist.

---

**Caution**—Class 1 Laser Product

- Do not look directly into a fiber-optic transceiver or into the ends of fiber-optic cables.
- Fiber-optic transceivers and fiber-optic cable connected to a transceiver emit laser light that can damage your eyes.
- Do not leave a fiber-optic transceiver uncovered except when inserting or removing cable.
- The safety cap keeps the port clean and prevents accidental exposure to laser light.
- Always inspect and clean the LC connector end faces before making any connections.

**ATTENTION**—Produit laser de classe 1

- Ne regardez pas directement dans un module fibre optique ou dans l'extrémité d'un câble fibre optique.
- Un module fibre optique et un câble fibre optique sont reliés à un émetteur qui émet un faisceau lumineux pouvant endommager la rétine.
- Ne laissez jamais un module fibre optique sans capuchon de sûreté excepté lors du branchement ou du débranchement d'un câble fibre optique.
- Le capuchon de sûreté garde l'orifice du module propre et empêche l'exposition accidentelle au faisceau laser.
- Inspectez et nettoyez toujours les contours du connecteur LC avant tout branchement.

**PRECAUCIÓN**—Producto Del Laser De la Clase 1

- No mire directamente en un transmisor-receptor fiber-optic o en los extremos de cables fiber-optic.
- Los transmisores-receptores fiber-optic y el cable fiber-optic conectaron con un transmisor-receptor emiten la luz laser que puede dañar sus ojos.
- No deje un transmisor-receptor fiber-optic destapado excepto al insertar o quitando el cable.
- El casquillo de seguridad guarda el portuario para limpiar y previene la exposición accidental a la luz laser.
- Examine y limpie siempre las caras del extremo del conector del LC antes de hacer cualesquiera conexiones.

**VORSICHT**—Klasse 1 Laser-Produkt

- Schauen Sie nicht direkt in einem Glasfaser-Transceiver oder in den Enden einer Lichtwellenleiter.
- Glasfaser-Transceiver-und LWL-Kabel emittieren Laserlicht, dass die Augen schädigen können.
- Lassen Sie ein Glasfaser-Transceiver zugedeckt , außer beim Einsetzen oder Entfernen von Kabel.
- Die Schutzkappe hält den Port sauber und verhindert ungewollte Belastungen durch Laserlicht.
- Ueberprüfen und reinigen Sie den LC-Stecker Enden bevor Sie jegliche Anschlüsse vornehmen.

## Compliance Statements

This section contains regulatory compliance statements for the RackSwitch G8000.

### Blade Network Technologies Commitment to WEEE

The EU Directive of the EU Parliament and Council on Waste Electrical and Electronic Equipment (WEEE) became effective on 13 August 2005. Individual EU Member State implementations were made effective, or will be effective, during 2005 and 2006.

BLADE is committed to be a responsible member of the global community in providing management of WEEE and is complying with all the obligations pursuant the WEEE Directive and its implementation in National Member State legislation as applicable.

Information for pursuing proper means for collection and treatment of WEEE from commercial customers resulting from products put on the market may be obtained by visiting our web site:

<http://www.bladenetwork.net/weee>

## Federal Communications Commission (FCC) Statement

**Note:** This equipment has been tested and found to comply with the limits for a Class A digital device, pursuant to Part 15 of the FCC Rules. These limits are designed to provide reasonable protection against harmful interference when the equipment is operated in a commercial environment. This equipment generates, uses, and can radiate radio frequency energy and, if not installed and used in accordance with the instruction manual, may cause harmful interference to radio communications. Operation of this equipment in a residential area is likely to cause harmful interference, in which case the user will be required to correct the interference at his own expense.

Properly shielded and grounded cables and connectors must be used in order to meet FCC emission limits. Blade Network Technologies, Inc. is not responsible for any radio or television interference caused by using other than recommended cables and connectors or by unauthorized changes or modifications to this equipment. Unauthorized changes or modifications could void the user's authority to operate the equipment.

This device complies with Part 15 of the FCC Rules. Operation is subject to the following two conditions: (1) this device may not cause harmful interference, and (2) this device must accept any interference received, including interference that may cause undesired operation.

## Industry Canada Class A Emission Compliance Statement

This Class A digital apparatus complies with Canadian ICES-003.

Avis de conformité à la réglementation d'Industrie Canada

Cet appareil numérique de la classe A est conforme à la norme NMB-003 du Canada.

## Australia and New Zealand Class A Statement

**Attention:** This is a Class A product. In a domestic environment this product may cause radio interference in which case the user may be required to take adequate measures.

## European Union EMC Directive Conformance Statement

This product is in conformity with the protection requirements of EU Council Directive 2004/108/EC on the approximation of the laws of the Member States relating to electromagnetic compatibility. Blade Network Technologies, Inc. cannot accept responsibility for any failure to satisfy the protection requirements resulting from a nonrecommended modification of the product, including the fitting of unsupported option cards.

This product has been tested and found to comply with the limits for Class A Information Technology Equipment according to CISPR 22/European Standard EN 55022. The limits for Class A equipment were derived for commercial and industrial environments to provide reasonable protection against interference with licensed communication equipment.

**Attention:** This is a Class A product. In a domestic environment this product may cause radio interference in which case the user may be required to take adequate measures.

## NOM Statement (Mexico only)

The following information is provided on the devices described in this document in compliance with the safety requirements of the Norma Oficial Mexicana (NOM):

Exporter:	Blade Network Technologies 2350 Mission College Blvd. Santa Clara, CA, 95054 USA
Importer:	IMPORSYS, S.A. de C.V.28 de Diciembre No. 22 Col. Avante, C.P. 04460 México, D.F.
Input:	RackSwitch G8000  G8000F AC 100-240 V~ 1.5 50-60 Hz Chassis power consumption: 150W  G8000R AC 100-240 V~ 1.5 50-60 Hz Chassis power consumption: 150W

## Información NOM (unicamente para México)

La información siguiente se proporciona en el dispositivo o en los dispositivos descritos en este documento, en cumplimiento con los requisitos de la Norma Oficial Mexicana (NOM):

Exportador:	Blade Network Technologies 2350 Mission College Blvd. Santa Clara, CA, 95054 USA
Importer:	IMPORSYS, S.A. de C.V.28 de Diciembre No. 22 Col. Avante, C.P. 04460 México, D.F.
Input:	RackSwitch G8000  G8000F AC 100-240 V~ 1.5 50-60 Hz Consumo de energía del chasis:: 150W  G8000R AC 100-240 V~ 1.5 50-60 Hz Consumo de energía del chasis:: 150W

## KCC/MIC Notice (Republic of Korea only)

This device has been approved for use in Business applications only per the Class A requirements of the Republic of Korea Ministry of Information and Communications (MIC). This device may not be sold for use in a non-business application.

Observe the Regulatory Marking label on the back or bottom of each switch for specific certification information pertaining to this model. Each RackSwitch G8000 model is approved for shipment to/usage in Korea and is labelled as such, with all appropriate text and the appropriate MIC reference number.

## Japanese Voluntary Control Council for Interference (VCCI) Statement

この装置は、情報処理装置等電波障害自主規制協議会（VCCI）の基準に基づくクラスA情報技術装置です。この装置を家庭環境で使用すると電波妨害を引き起こすことがあります。この場合には使用者が適切な対策を講ずるよう要求されることがあります。

## Denan Statement (Japan/Nippon only)

本製品を安全にご使用いただくため、以下のことにご注意ください。

- 接続ケーブル、電源コード、ACアダプタなどの部品は、必ず製品に同梱されている添付品または指定品をご使用ください。添付品・指定品以外の部品をご使用されることは動作不良、火災の原因となることがあります。
- 同梱されております付属の電源コードを他の機器には使用しないでください。本注意事項を守らないと、死亡や大怪我など人身事故の原因となることがあります。

# 有毒有害物质或元素名称及含量标识

Toxic / Hazardous Substances and Elements Table (RackSwitch G8000F/G8000R)

部件名称	有毒有害物质或元素					
	铅 (Pb)	汞 (Hg)	镉 (Cd)	六价铬 (Cr (VI))	多溴联苯 (PBB)	多溴二苯醚 (PBDE)
外部盖板 external covers	○	○	○	○	○	○
空气传动设备 air moving devices	○	○	○	○	○	○
处理器模块 processor modules	×	○	○	○	○	○
电缆组合件 cable assemblies	○	○	○	○	○	○
电源 power supply	○	○	○	○	○	○
有 mech 的电路卡 circuit cards with mechs	○	○	○	○	○	○
无 mech 的电路卡 circuit cards w/o mechs	○	○	○	○	○	○

○：表示该有毒有害物质在该部件所有均质材料中的含量均在SJ/T 11363—2006规定的限量要求以下。

o: Indicates that the content of the toxic and hazardous substance in all the homogeneous materials of the part is below the concentration limit requirement as described in SJ/T 11363-2006.

×：表示该有毒有害物质至少在该部件的某一均质材料中的含量超出SJ/T 11363—2006规定的限量要求。

x: Indicates that the content of the toxic and hazardous substance in at least one homogeneous material of the part exceeds the concentration limit requirement as described in SJ/T 11363-2006.

环保使用期限 (EPUP) 的免责条款: EPUP 规定的具体期限仅为符合中华人民共和国的相应的法律规定, 并非代表 **BNT** 向客户提供保证或负有任何义务。EPUP 中假定客户按照操作手册在正常情况下使用本产品。

Environmental Protection Use Period (EPUP) Disclaimer: The number provided as the EPUP is provided solely to comply with applicable laws of the People's Republic of China. It does not create any warranties or liabilities on behalf of BNT to customers. The EPUP assumes that the product will be used under normal conditions in accordance with the BNT operating manual.

Blade Part #: BN-8000R-F and BN-8000F-F  
IBM Part #: 46C3407 and 46C3403



2350 Mission College Blvd.  
Suite 600  
Santa Clara, CA 95054  
[www.bladenetwork.net](http://www.bladenetwork.net)